

lamaPLC: LTC3588 - Nanopower energy harvesting power supply IC

Energy harvesting (*EH*) – also known as power harvesting, energy scavenging, or ambient power – is the process by which energy is derived from external sources (e.g., *solar power*, *thermal energy*, *wind energy*, *salinity gradients*, and *kinetic energy*, also known as *ambient energy*), then stored for use by small, wireless autonomous devices, like those used in wearable electronics, condition monitoring, and wireless sensor networks.



Energy harvesters typically deliver only a small amount of power to low-power electronics. While the input fuel for some large-scale energy generation requires resources (oil, coal, etc.), the energy source for energy harvesters is ambient. For example, temperature gradients are generated by a combustion engine, and in urban areas, the environment contains significant electromagnetic energy due to radio and television broadcasting.

One of the first examples of ambient energy being used to produce electricity was the successful use of electromagnetic radiation (EMR) to generate the crystal radio.



If you'd like to support the development of the site with the price of a coffee — or a few — [please do so here](#).

Here's a handy tip: you can quickly save this page as a PDF by clicking "export to PDF" in the menu on the right side of the screen.

2026/02/14 23:38

LTC-3588 Features

V_{IN}: -0.3V to 18V (has an internal 20V clamp)

I_{SW}: 0A .. 25mA

PZ1, PZ2: 0V .. V_{IN}

D0, D1: -0.3V .. [Lesser of (V_{IN2} + 0.3V) or 6V]

CAP: [Higher of -0.3V or (V_{IN} - 6V)] .. V_{IN}

V_{IN2}: -0.3V .. [Lesser of (V_{IN} + 0.3V) or 6V]

V_{OUT}: -0.3V .. Lesser of (V_{IN2} + 0.3V) or 6V

PGOOD: -0.3V to Lesser of (V_{OUT} + 0.3V) or 6V

The primary differences between the LTC3588-1 and the LTC3588-2 are their selectable output-voltage ranges and input undervoltage lockout (UVLO) thresholds, which optimize each for different input sources.

Feature	LTC3588-1	LTC3588-2
Selectable Output Voltages	1.8V, 2.5V, 3.3V, or 3.6V	3.45V, 4.1V, 4.5V, or 5.0V
Input Operating Range	2.7V to 20V	14V to 20V
UVLO Rising Threshold	Lower (e.g., ~3.8V in testing)	Higher (16V)
Quiescent Current (in UVLO)	450nA	830nA (at VIN=12V)
Quiescent Current (in regulation)	950nA	1500nA (at VIN=18V)

Pin functions

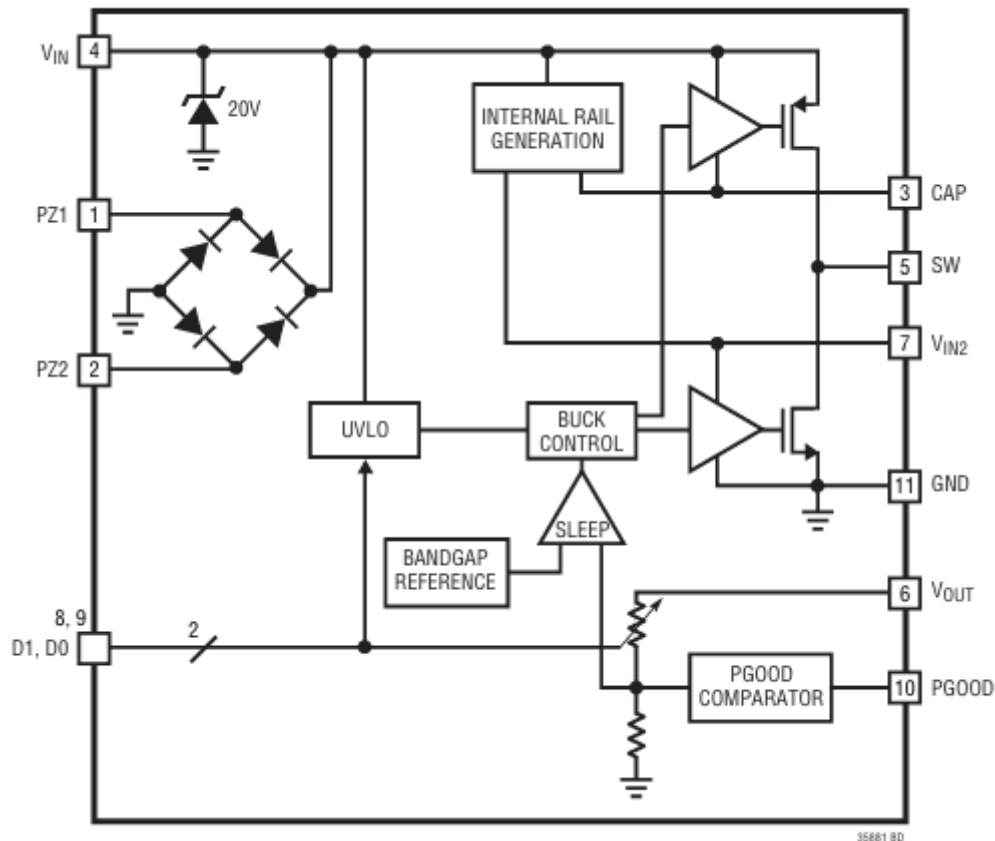

- **PZ1 (Pin 1):** Input connection for piezoelectric element or other AC source (used in conjunction with PZ2).
- **PZ2 (Pin 2):** Input connection for piezoelectric element or other AC source (used in conjunction with PZ1).
- **CAP (Pin 3):** Internal rail referenced to VIN to serve as gate drive for buck PMOS switch. A 1 μ F capacitor should be connected between CAP and VIN. This pin is not intended for use as an external system rail.
- **VIN (Pin 4):** Rectified Input Voltage. A capacitor on this pin serves as an energy reservoir and input supply for the buck regulator. The VIN voltage is internally clamped to a maximum of 20V (typical).
- **SW (Pin 5):** Switch Pin for the Buck Switching Regulator. A 10 μ H or larger inductor should be connected from SW to VOUT.
- **VOUT (Pin 6):** Sense pin used to monitor the output voltage and adjust it through internal feedback.
- **VIN2 (Pin 7):** Internal low voltage rail to serve as gate drive for buck NMOS switch. Also serves as a logic-high rail for the output-voltage select bits D0 and D1. A 4.7 μ F capacitor should be connected from VIN2 to GND. This pin is not intended for use as an external system rail.

- **D1 (Pin 8):** Output Voltage Select Bit. D1 should be tied high to VIN2 or low to GND to select the desired VOUT (see Table 1).
- **D0 (Pin 9):** Output Voltage Select Bit. D0 should be tied high to VIN2 or low to GND to select the desired VOUT (see Table 1).
- **PGOOD (Pin 10):** Power good output is logic high when VOUT is above 92% of the target value. The logic high is referenced to the VOUT rail.
- **GND (Exposed Pad Pin 11):** Ground. The Exposed Pad should be connected to a continuous ground plane on the second layer of the printed circuit board by several vias directly under the LTC3588-1.

LTC-3588 Nanopower Energy Harvesting Power Supply

The **LTC®3588-1** integrates a low-loss full-wave bridge rectifier with a high-efficiency buck converter to form a complete energy-harvesting solution optimized for high-output-impedance energy sources such as piezoelectric, solar, or magnetic transducers. An **ultralow quiescent current undervoltage lockout (UVLO)** mode with a wide hysteresis window allows charge to accumulate on an input capacitor until the buck converter can efficiently transfer a portion of the stored charge to the output.

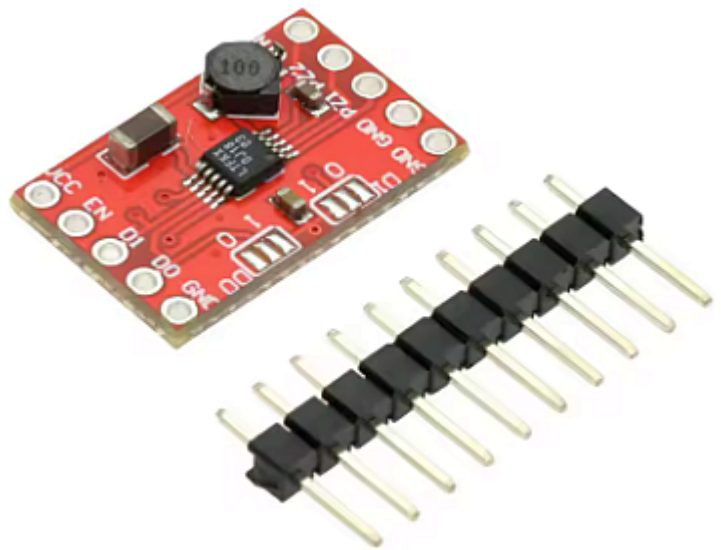

In regulation, the LTC3588-1 enters a sleep state in which both input and output quiescent currents are minimal. The buck converter turns on and off as needed to maintain regulation. Four output voltages, 1.8V, 2.5V, 3.3V, and 3.6V, are pin selectable with up to 100mA of continuous output current; however, the output capacitor may be sized to service a higher output current burst.

An input protective shunt set to 20V enables greater energy storage for a given input capacitance.

Typical application

100mA Piezoelectric Energy Harvesting Power Supply

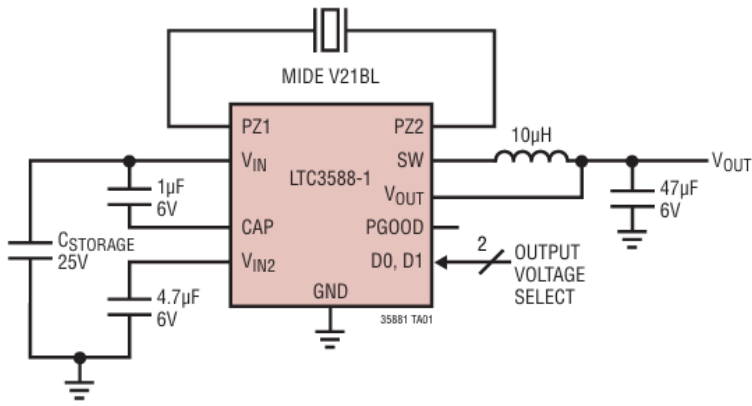

LTC3588-1 3.3V Regulator Start-Up Profile

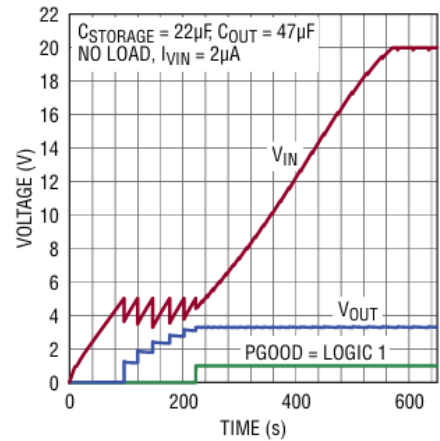

LTC-3588 with Solar-Powered 2.5V Supply

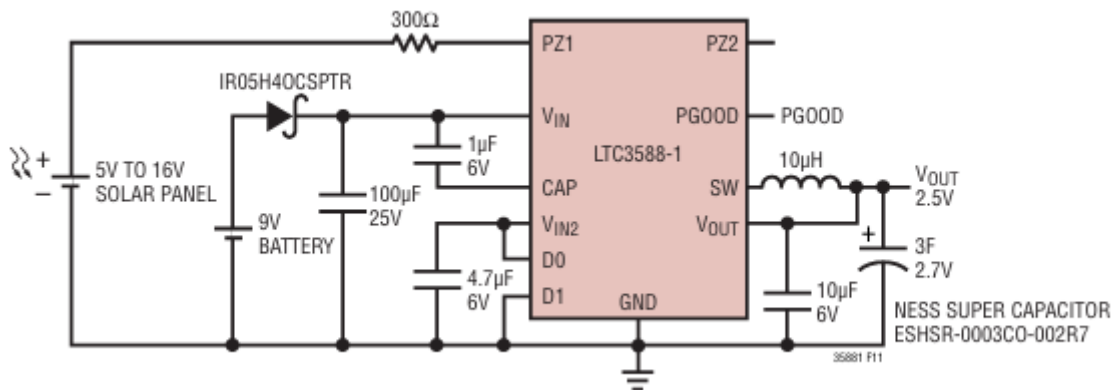

5V to 16V Solar-Powered 2.5V Supply with Supercapacitor for Increased Output Energy Storage and Battery Backup

LTC-3588 with Thermoelectric

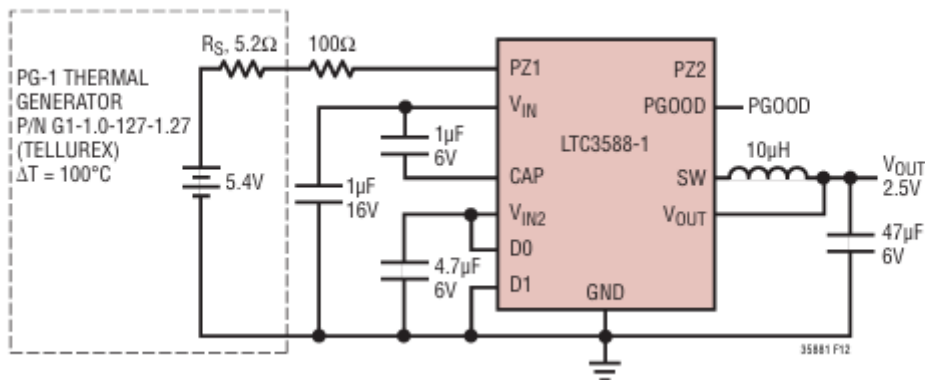

Thermoelectric Energy Harvester

LTC-3588 with Piezoelectric

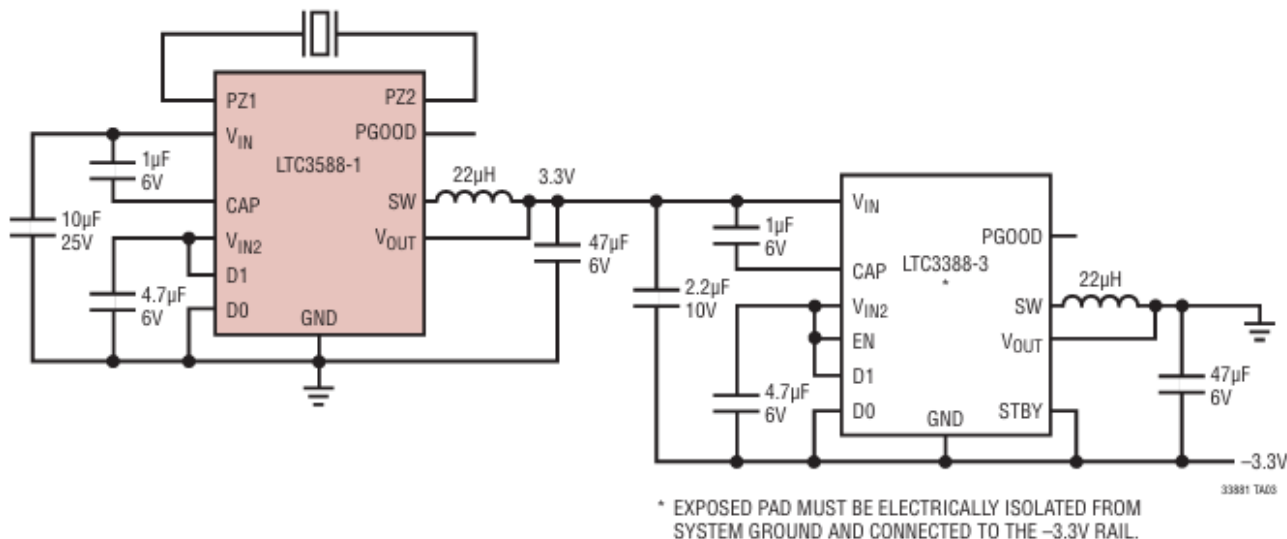

Piezoelectric Energy Harvester with ±3.3V Outputs

More information: <https://www.analog.com/en/products/ltc3588-1.html>

Sensor topics on lamaPLC

Page	Date	Tags
<ul style="list-style-type: none"> • lamaPLC project: Arduino - OLED SH1106 with AHT20/BMP280 Sensor 	2026/04/23 21:51	bmp280 , aht20 , temperature , humidity , pressure , sensor , arduino , oled , sh1106 , arduino code
<ul style="list-style-type: none"> • lamaPLC project: Arduino - Vibration sensors 	2026/04/15 17:21	vibration , sensor , piezoelectric , mems , eddy-current , electrodynamic , gxfm0459 , ldtm-028k , arduino , arduino code
<ul style="list-style-type: none"> • lamaPLC project: Digitales Potentiometer Board Moduls 	2026/04/11 18:29	sensor , module , arduino code , renesas , x9c series , x9c102 , x9c103 , x9c104 , x9c503 , xdcp , digitally controlled potentiometer
<ul style="list-style-type: none"> • lamaPLC project: Sension SCD CO² measurement module 	2026/04/15 19:34	scd30 , scd40 , scd41 , iaq , ndir , sensor , i2c , arduino code
<ul style="list-style-type: none"> • lamaPLC: A0221AU / A02YYUW Waterproof Ultrasonic Distance Sensor with UART communication 	2026/04/23 21:52	a0221au , a02yyuw , waterproof , ultrasonic , distance , sensor , uart , ip67 , serial , sen0311 , dfrobot
<ul style="list-style-type: none"> • LamaPLC: AHT10 Modul 	2026/03/22 03:14	communication , i2c , temperature , humidity , sensor , aht , aht 10 , modul
<ul style="list-style-type: none"> • LamaPLC: AHT20 / BMP280 Modul 	2026/04/23 21:52	bmp280 , aht20 , adafruit , temperature , humidity , pressure , sensor , arduino , code , i2c
<ul style="list-style-type: none"> • LamaPLC: Allegro ACS758 Hall-effect linear current sensors 	2026/04/23 21:52	cjmcu , cjmcu-758 , acs758 , acs758lcb-050b , acs758lcb-100b , acs758kcb-150b , acs758ecb-200b , hall-effect , current , sensor , analog , arduino , code

• LamaPLC: APDS - Avago ALS and proximity detection sensors with I ² C communication	2026/04/23 21:52	avago, apds-9900, apds-9930, apds-9960, als, proximity, detection, gesture recognition, gesture, i2c, communication, sensor, arduino, code
• lamaPLC: Arduino Modul: BME680	2026/05/12 18:40	code, c, 2026, arduino, bme680, sensor, i2c, comunication
• lamaPLC: AS5600 Magnetic Induction Angle Measurement Sensor Module	2026/05/13 00:06	communication, i2c, as5600, as-5600, magnetic, induction, angle, sensor
• LamaPLC: BMP/BME Bosch Temperature/Humidity/Pressure sensors with I ² C communication	2026/04/23 21:52	bme280, bme680, bme688, bmp180, bmp280, hw-611, hw611, bosch, temperature, humidity, pressure, sensor, arduino, i2c, communication, ai, cjmcu, volatile organic compounds, vocs, volatile sulfur compounds, vscs, iaq
• LamaPLC: BQ25570 / CJMCU-2557 - Texas Instruments nano-power management IC and module	2026/04/23 21:52	bq25570, sensor, texas instruments, nano-power management, dc-dc boost charger, mppt, solar, thermoelectric, piezoelectric, energy harvesting, eh
• LamaPLC: CJMCU-219/INA-219 breakout board/IC with I ² C communication	2026/04/23 21:52	cjmcu-219, ina-219, ina219, breakout board, i2c, communication, sensor, voltage, current, arduino, code, cjmcu
• LamaPLC: CJMCU-3216 / AP-3216 integrated digital ambient light and proximity sensor module/IC with I ² C communication	2026/04/23 21:52	cjmcu-3216, cjmcu, ap-3216, ap3216, ambient light, proximity, sensor, arduino, code, i2c, communication
• LamaPLC: CJMCU-3901/PMW-3901 compact optical flow sensor module/IC by PixArt with SPI communication	2026/04/23 21:52	cjmcu-3901, cjmcu, pmw3901, pmw-3901, optical flow, sensor, pixart, spi, communication, arduino, code, pmw3901mb-txqt
• LamaPLC: CJMCU-6701: Biosensor for measuring Galvanic Skin Response (GSR) with SPI communication	2026/04/23 21:52	cjmcu, cjmcu-6701, acs758, acs-758, galvanic skin response, gsr, electrodermal activity, eda, spi, communication, arduino, code, sensor, healthcare
• LamaPLC: CJMCU-6814 combined gas sensor module for CO, NO ₂ , NH ₃	2026/04/23 21:52	analog, cjmcu, cjmcu-6814, mics6814, mics-6814, sensor, arduino, code, carbon monoxide, co, ammonia, nh ₃ , nitrogen dioxide, no ₂
• lamaPLC: CJMCU-811 CCS811 Gas Sensor (VOCs TVOC CO ₂)	2026/04/23 21:52	cjmcu-811, ccs811, gas, sensor, vocs, tvoc, eco2, co2, arduino, air quality metal oxide, mox, i2c, micropython, rp2040-eth
• LamaPLC: CJMCU-8221 Analog Devices Precision instrumentation amplifier module	2026/04/23 21:52	cjmcu-8221, ad8221ar, analog devices, amplifier, sensor, cjmcu
• LamaPLC: D6T Omron Non-Contact Thermal Sensors with I ² C communication	2026/04/23 21:52	d6t, d6t-32l, d6t-44l, d6t-8l, d6t-1a, omron, non-contact, thermal, sensor, i2c, arduino, code
• LamaPLC: DHT Temperature /Humidity sensors with 1-wire / I ² C communication	2026/04/23 21:52	dht11, dht20, dht22, temperature, humidity, pressure, sensor, 1-wire, arduino, code

• LamaPLC: DPS Infineon Temperature/Pressure sensors with I2C communication	2026/04/23 21:52	dps310, infineon, temperature, pressure, sensor, arduino, i2c, communication, code
• lamaPLC: DS18B20 1-Wire Digital Thermometer	2026/04/23 21:52	ds18b20, sensor, 1-wire, communication, arduino, thermometer, parasitic mode
• lamaPLC: Energy, power, current, and voltage	2025/05/31 23:32	i2c, i c, communication, arduino, energy, power, current, sensor, ina226
• LamaPLC: ENS ScioSense Multi-gas sensors with I ² C communication	2026/04/23 21:52	ens160, sciosense, gas-quality, i2c, communication, sensor, arduino, code, eco2, tvoc, aqi, indoor air quality, iaq, co2, voc
• lamaPLC: ENS160 + AHT21 Air Quality Sensor - CO, ECO, TVOC, Temp & Humidity Module	2026/04/23 21:52	arduino, ens160, aht21, air quality, sensor, co, eco, tvoc, module, aqi
• LamaPLC: Gas sensors	2023/07/01 17:29	gas, sensor, i2c, onewire, communication, mq-3, mq-4, mq-5, mq-6, mq-7, mq-8, mq-9, mq-135, gm-102b, gm-302b, gm-502b, gm-702b, alcohol, ch4, natural gas, smoke, lng, co, co2, lpg, h2, iso-butane, nox, nh3, benzene, town gas, formaldehyde, propane, humidity, temperature, voc, grv gas sens v2
• LamaPLC: GM MEMS Gas-sensors	2026/04/23 21:52	gm-102b, gm-302b, gm-502b, gm-702b, mems, gas-quality, sensor, arduino, code, nitrogen dioxide, no2, volatile organic compounds, voc, carbon monoxide, co, ethyl alcohol, c2h5ch, formaldehyde, ch2o, alcohol, c2h5oh
• lamaPLC: GY-511 6DOF sensor module	2026/04/23 21:52	stmicroelectronics, lsm303dlhc, i2c, lsm303, sensor, gy-511, 6dof, pololu, module, arduino
• LamaPLC: HC-SR04 Ultrasonic Sensor Module	2026/04/23 21:52	hc-sr04, ultrasonic, sensor, arduino, code
• LamaPLC: HDC Texas Instruments Temperature/humidity sensors with I ² C communication	2026/04/23 21:52	sht21, htu21, si7021, gy-21, gy-213v, hdc1080, gy-213v-hdc1080, cjmcu, cjmcu-1080, texas instruments, temperature, humidity, sensor, i2c, communication, arduino, code
• LamaPLC: HTU TE Connectivity temperature/humidity sensors with I ² C communication	2026/04/23 21:52	htu, htu31d, htu21d, htu20d, sht20, htu20, sht21, htu21, si7021, gy-21, gy-213v, hdc1080, si702, gy-20, sht31, htu31, si7031, gy-31, te connectivity, temperature, humidity, i2c, communication, sensor, arduino, code
• LamaPLC: HX711 24-bit analog-to-digital converter (ADC)	2026/04/11 18:28	hx711, hx-711, analog-to-digital, adc, converter, load cell, wheatstone bridge, weight, sensor, communication, arduino, code

• lamaPLC: INA modules with Arduino libraries	2026/04/23 21:52	i2c , i c , communication , arduino , energy , power , current , monitor , sensor , ina219 , gy-219 , ina226 , gy-216 , ina228 , gy-228 , ina237 , ina238 , ina260 , ina3221 , ina
• lamaPLC: INA226 - current/voltage/power monitor with I²C communication	2026/04/23 21:52	i2c , i c , communication , arduino , energy , power , current , monitor , sensor , ina226 , ina219 , ina
• lamaPLC: LTC3588 - Nanopower energy harvesting power supply IC	2026/04/23 21:52	communication , arduino , sensor , energy harvesting , eh , energy , ambient power
• LamaPLC: M01 - V0.4 Laser ranging sensor with UART communication	2026/04/23 21:52	distance measurement , laser , distance , sensor , m01
• LamaPLC: MAX30100/MAX30102 Heart Rate Click Sensor Module	2026/04/23 21:52	max30102 , max30100 , heart rate click , sensor , communication , i2c , arduino , code
• lamaPLC: Max31865 RTD to Digital Converter - PT100/PT1000 Platine	2026/04/23 21:52	max31865 , rtd , pt 100 , pt 1000 , temperature , spi , platinum , arduino , code , sensor , adafruit
• LamaPLC: MAX4466/MAX9814: Low-noise Microphone Preamplifiers	2026/04/23 21:52	audio , microphone , analogue audio , max4466 , max9814 , max 4466 , max 9814 , agc , preamplifiers , sensor , arduino , code
• LamaPLC: MH-Z19 series of NDIR CO₂ sensors	2026/04/23 21:52	mh-z19 , mh-z19d , mh-z19c , mh-z19b , mh-z19e , ndir , co₂ , sensor , winsen , uart , pwm , communication , non-dispersive infrared , infrared , ir , temperature , arduino , code , tasmota
• lamaPLC: MPU-6050 (HW-123, GY-521) 6-axis MotionTracking device	2026/04/23 21:52	mpu-6050 , hw-123 , gy-521 , 6-axis motiontracking , dmp , temperature , sensor , mems , arduino code , arduino , accelerometer , gyroscope , tilt
• LamaPLC: MQ Winsen Gas-sensors	2026/04/23 21:52	mq , mq-2 , mq-3 , mq-4 , mq-5 , mq-6 , mq-7 , mq-8 , mq-9 , mq-131 , mq-135 , mq-137 , winsen , gas-sensor , sensor , arduino , code , alcohol , c₂h₅oh , benzine gas , smoke , lpg , propane , c₃h₈ , hydrogen , h₂ , methane , ch₄ , iso-butane , town gas , ammonia , nh₃
• LamaPLC: PIR sensors	2026/04/23 21:52	hc-sr501 , hc-sr505 , am-312 , ekmb ekmc , pir , motion , sensor , arduino , code
• LamaPLC: Pixart PAJ7620U2 Gesture recognition sensors/module with I²C communication	2026/04/23 21:52	paj7620u2 , gy-paj7620 , pixart , gesture recognition , i2c , communication , sensor , arduino , code
• lamaPLC: PT100 / PT1000	2025/09/23 18:59	pt100 , pt1000 , temperature , sensor , platine , rtd
• lamaPLC: PTA8C04 4-channel PT100 Modbus Modul	2026/02/14 18:42	pta8c04 , sensor , modbus , rtu , rs-485 , communication , platine , um72
• LamaPLC: RCWL - Microwave radar sensor	2026/04/23 21:52	rcwl-0516 , rcwl , microwave , radar , sensor , arduino , code
• lamaPLC: RD-xx - Ai-Thinker Radar Module with UART communication	2026/04/23 21:52	radar , s3km1110 , fmcw , rd-01 , rd-03 , rd-03d , ai-thinker , k-band , 24 ghz , sensor , distance , micro-movements

• lamaPLC: RP2040_ETH_Modul: Read BME 680/688 sensor data	2026/05/12 21:06	code, micropython, 2026, rp2040 eth, bme680, i2c, sensor, communication
• lamaPLC: RP2040_ETH_Modul: Read BME 680/688 sensor data and store in Modbus input registers	2026/05/12 18:58	code, micropython, 2026, rp2040 eth, bme680, i2c, sensor, communication
• LamaPLC: SGP Sensirion TVOC/VOC sensors with I ² C communication	2026/04/15 19:41	sgp30, sgp40, sgp41, sensirion, gas-sensor, i2c, communication, sensor, arduino, code, eco2, voc, tvoc, indoor air quality, iaq, nox, hydrogen
• LamaPLC: SHT Sensirion Temperature/humidity sensor with I ² C communication	2026/04/23 21:52	sht20, sht21, sht25, sht30, sht31, sht35, sht40, gy21, temperature, humidity, i2c, communication, sensor, arduino, code
• LamaPLC: Texas Instruments ADCs: Delta-sigma multi-channel Analog Converters with SPI communication	2026/04/23 21:52	ads111x, ads12xx, delta-sigma, converter, texas instruments, adc, spi, communication, sensor, arduino, code, ads1110, ads1112, ads1113, ads1114, ads1115, ads1118, ads1119, ads1220, ads1232, ads1234, ads1256, ads1261, ads1263, multi channel
• LamaPLC: TOFnnnC STMicroelectronics Time-of-Flight (ToF) sensors with I ² C communication	2026/04/23 21:52	tof050c, vl6180, tof200c, vl53l0x, tof400c, vl53l1x, stmicroelectronics, time-of-flight, tof, i2c, communication, sensor, arduino, code
• LamaPLC: UICPAL Temp.humi.sensor	2023/06/25 00:43	simatic, s7, modbus, communication, temperature, humidity, sensor
• LamaPLC: VL53Lnn STMicroelectronics time-of-flight (ToF) laser-ranging sensors with I ² C communication	2026/04/23 21:52	vl53l0x, vl53l1x, vl53l0 1xv2, gy-530, time-of-flight, tof, laser-ranging, i2c, communication, sensor, arduino, code
• LamaPLC: VL6180X STMicroelectronics Time-of-Flight (ToF) sensor with I ² C communication	2026/04/23 21:52	vl6180x, stmicroelectronics, time-of-flight, tof, i2c, communication, sensor, arduino, code
• LamaPLC: Waveshare TOF Laser Range Sensor with UART / I ² C communication	2026/04/23 21:52	distance measurement, laser, range, sensor, tof, waveshare
• lamaPLC: XGZP68xx: Silicon Pressure Sensors/Module	2026/05/15 15:17	communication, i2c, sensor, modul, pressure, cfsensor, xgzp68xx, xgzp6810d, xgzp6857d, xgzp6859d, xgzp6887d, xgzp6897d, xgzp6899a, piezoresistive, capacitive
• lamaPLC: YR-3180 - Weight sensor module with UART or Modbus communication	2026/02/15 00:00	communication, modbus, rtu, sensor, weight, yr-3180, hx710b, arduino, ttl, rs-485
• LM393: Dual differential comparator (flame, light, sound sensors)	2026/05/12 22:18	communication, analog, lm393, lm-393, flame, ir, sound, hall, sensor, ky-026, hw-484, ky-037, ky-038, fc-03, hc-89, ky-024, modul
• Magnetic angle sensors	2026/03/05 21:19	magnetic angle sensor, magnetic flux, sensor, spi, i2c, pwm, communication, modul, as5047p, as5600, mt6701, mt6816, mt6835, tle5012b, amr, gmr, tmr, anisotropic magnetoresistive

- [NT18B07: 7 Kanal RS485 Temperatur Sensor with Modbus RTU](#) 2026/02/14 18:49 [nt18b07](#), [sensor](#), [modbus](#), [rtu](#), [rs-485](#), [communication](#), [platine](#)
- [PT100 / PT1000 sensors](#) 2026/04/23 21:52 [rtd](#), [pt100](#), [pt1000](#), [sensor](#), [temperature](#)
- [Radar Module RD-xx](#) 2026/04/23 21:52 [radar](#), [s3km1110](#), [fmcw](#), [rd-03](#), [k-band](#), [24 ghz](#), [sensor](#), [distance](#), [micro-movements](#)

[communication](#), [Arduino](#), [sensor](#), [energy harvesting](#), [EH](#), [energy](#), [ambient power](#)

This page has been accessed for: Today: 2, Until now: 192

From:
<https://www.lamaplc.com/> - **lamaPLC**

Permanent link:
<https://www.lamaplc.com/doku.php?id=sensor:l3c3588>

Last update: **2026/05/06 22:57**

